

# 軸心支持座 **SK**

## 底端固定

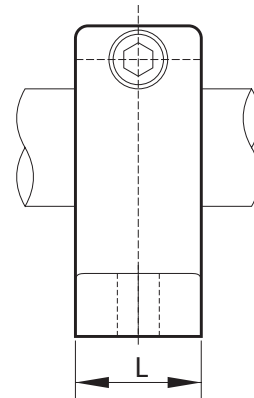

型號 MODEL NO	軸徑 SHAFT DIAMETER	主要尺寸 MAIN DIMENSIONS									鎖緊螺栓 DESIGNATION OF CLAMPING BLOT	安裝螺栓 DESIGNATION OF MOUNTING BLOT	重量 WEIGHT (g)
		H	E	W	L	F	G	P	B	S			
SK03	3	20	21	42	14	32.8	6	18	32	5.5	M4	M5	24
SK04	4	20	21	42	14	32.8	6	18	32	5.5	M4	M5	24
SK05	5	20	21	42	14	32.8	6	18	32	5.5	M4	M5	24
SK06	6	20	21	42	14	32.8	6	18	32	5.5	M4	M5	24
SK08	8	20	21	42	14	32.8	6	18	32	5.5	M4	M5	24
SK10	10	20	21	42	14	32.8	6	18	32	5.5	M4	M5	24
SK12	12	23	21	42	14	37.5	6	20	32	5.5	M4	M5	30
SK13	13	23	21	42	14	37.5	6	20	32	5.5	M4	M5	30
SK16	16	27	24	48	16	44	8	25	38	5.5	M4	M5	40
SK20	20	31	30	60	20	51	10	30	45	6.6	M5	M6	70
SK25	25	35	35	70	24	60	12	38	56	6.6	M6	M6	130
SK30	30	42	42	84	28	70	12	44	64	9	M6	M8	180
SK35	35	50	49	98	32	82	15	50	74	11	M8	M10	270
SK40	40	60	57	114	36	96	15	60	90	11	M8	M10	420
SK50	50	70	63	126	40	120	18	74	100	14	M12	M12	750
SK60	60	80	74	148	45	136	18	90	120	14	M12	M12	1100

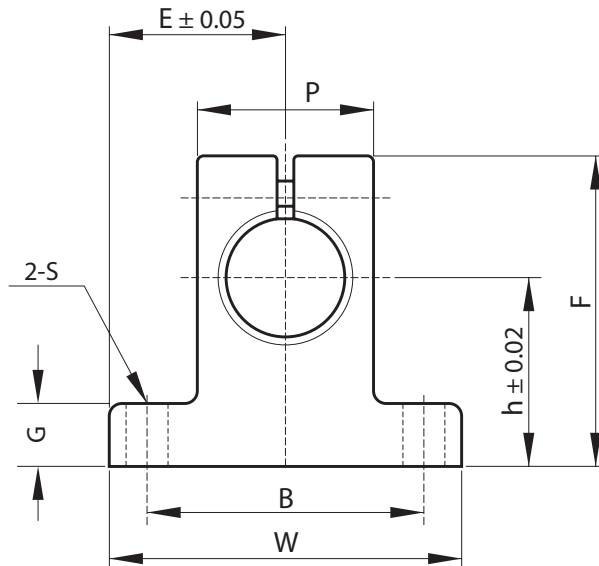
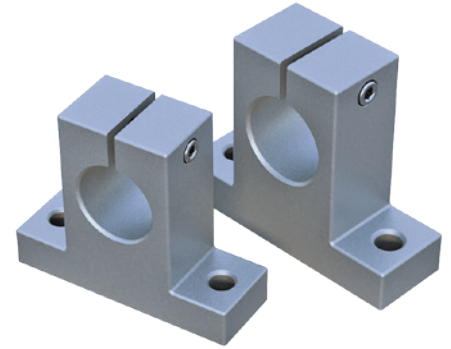

# 軸心支持座 SHF

## 側端固定

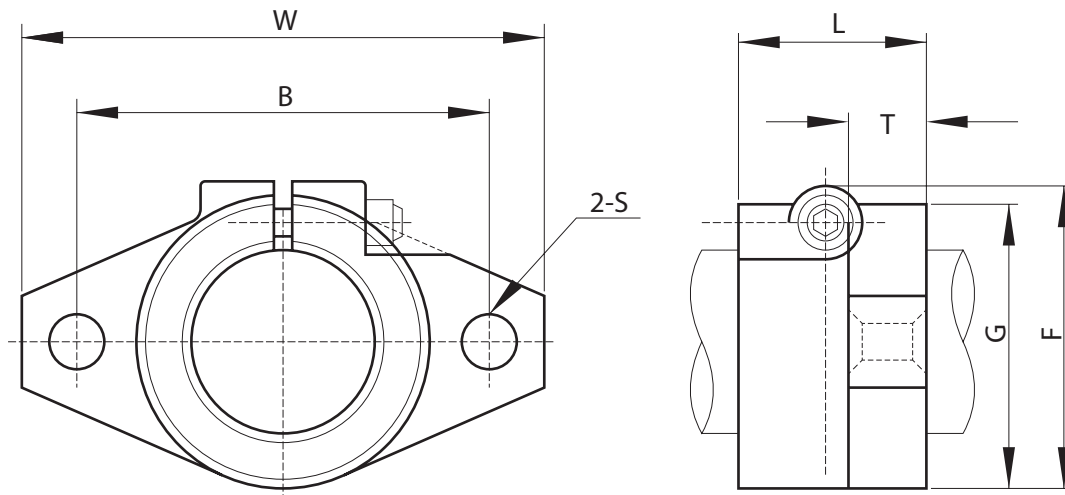
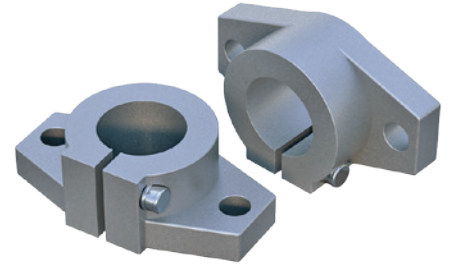

型號 MODEL NO	軸徑 SHAFT DIAMETER	主要尺寸 MAIN DIMENSIONS							鎖緊螺栓 DESIGNATION OF CLAMPING BLOT	安裝螺栓 DESIGNATION OF MOUNTING BLOT	重量 WEIGHT (g)
		W	L	T	F	G	B	S			
SHF3	3	43	10	5	24	20	32	5.5	M4	M5	13
SHF4	4	43	10	5	24	20	32	5.5	M4	M5	13
SHF5	5	43	10	5	24	20	32	5.5	M4	M5	13
SHF6	6	43	10	5	24	20	32	5.5	M4	M5	13
SHF8	8	43	10	5	24	20	32	5.5	M4	M5	13
SHF10	10	43	10	5	24	20	32	5.5	M4	M5	13
SHF12	12	47	13	7	28	25	36	5.5	M4	M5	20
SHF13	13	47	13	7	28	25	36	5.5	M4	M5	20
SHF16	16	50	16	8	31	28	40	5.5	M4	M5	27
SHF20	20	60	20	8	37	34	48	7	M5	M6	40
SHF25	25	70	25	10	42	40	56	7	M6	M6	60
SHF30	30	80	30	12	50	46	64	9	M6	M8	110
SHF35	35	92	35	14	58	50	72	12	M8	M10	380
SHF40	40	102	40	16	67	56	80	12	M10	M10	510
SHF50	50	122	50	19	83	70	96	14	M12	M12	890
SHF60	60	140	60	23	95	82	112	14	M12	M12	1500

# 軸心支持座 SA

## 外徑攻牙

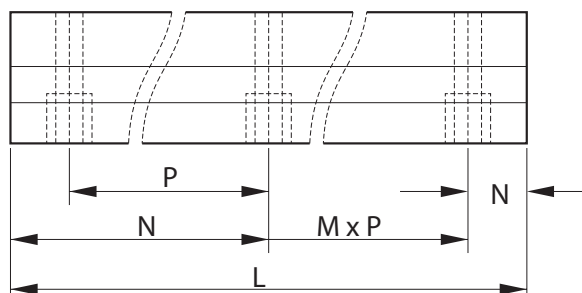
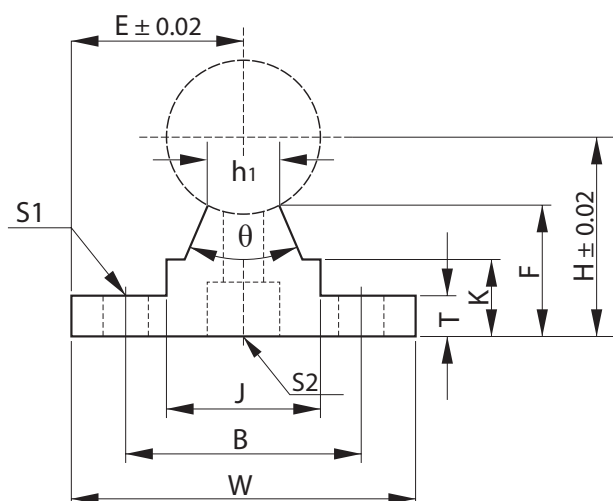
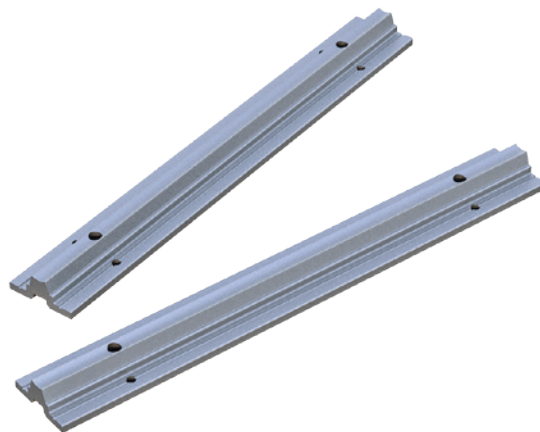

型號 MODEL NO	軸徑 SHAFT DIAMETER	主要尺寸 MAIN DIMENSIONS										安裝螺栓 MOUNTING DIMENSIONS				重量 WEIGHT (g)		
		H	E	W	L	F	T	K	J	h1	θ	B	N	M x P	S1		S2	
SA16-200	16	25	20	40	200	17.8	5	11.7	18.5	8	80°	30	25	1 X 150	5.5	M5	0.200	
SA16-300					300								75	1 X 150				0.300
SA16-400					400								50	2 X 150				0.400
SA16-500					500								25	3 X 150				0.500
SA16-600					600								75	3 X 150				0.600
SA20-200	20	27	22.5	45	200	17.7	5	10	19	8	50°	30	25	1 X 150	5.5	M6	0.200	
SA20-300					300								75	1 X 150				0.300
SA20-400					400								50	2 X 150				0.400
SA20-500					500								25	3 X 150				0.510
SA20-600					600								75	3 X 150				0.610
SA25-200	25	33	27.5	55	200	21	6	12	21.5	8	50°	35	25	1 X 150	6.5	M6	0.290	
SA25-300					300								50	1 X 200				0.430
SA25-400					400								100	1 X 200				0.580
SA25-500					500								50	2 X 200				0.730
SA25-600					600								100	2 X 200				0.880
SA30-200	30	37	30	60	200	22.8	7	13	26.5	10.3	50°	40	25	1 X 150	6.5	M8	0.360	
SA30-300					300								50	1 X 200				0.550
SA30-400					400								100	1 X 200				0.730
SA30-500					500								50	2 X 200				0.920
SA30-600					600								100	2 X 200				1.100