

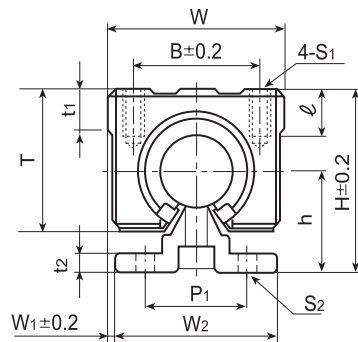

Anticorrosive Linear Guide

LMC - S25 - B2 - 2400

Model Shaft dia Block Rail length

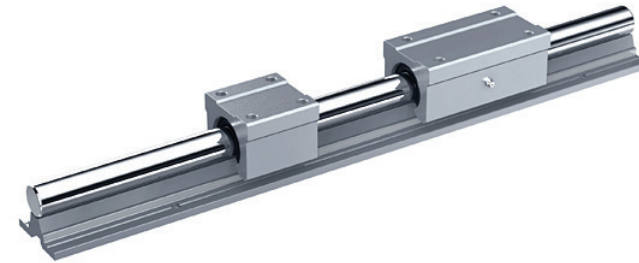

LMC-C
LMC-C16~ LMC-C40

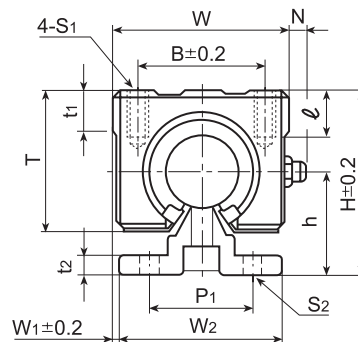

LMCL-C Long Type
LMCL-C16~ LMCL-C30

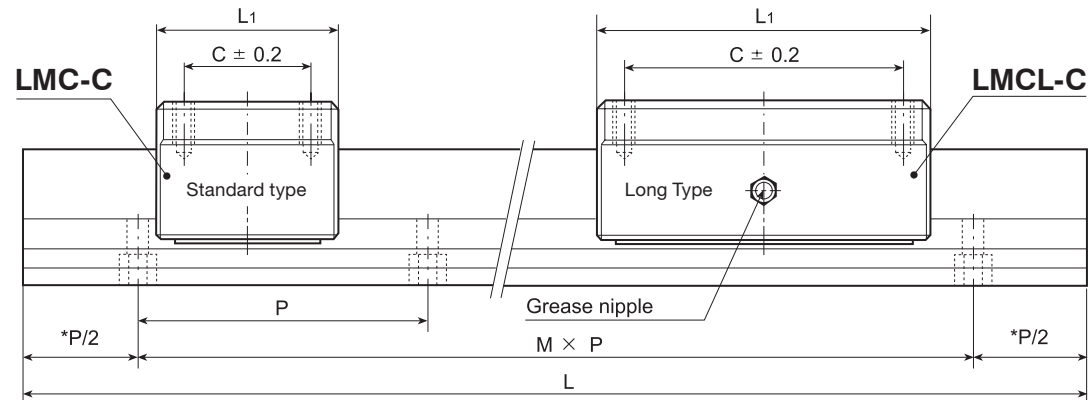

Note : * is to be changed by the length L.

Model No.	Shaft ØDia.	Mounting dimensions				Block dimensions				Rail dimensions										Basic Dynamic load rating C kgf	Basic Static load rating C ₀ kgf
		H	h	W ₁	W	L ₁	B	C	t ₁	S ₁	T	N	W ₂	P ₁	t ₂	P	S ₂	L (max)			
LMC-C16	16	45	25	2.5	45	45	32	30	9	12	M5	33	-	40	30	5	150	5.5	3,600	79	120
LMCL-C16						85		60					8							158	240
LMC-C20	20	50	27	1.5	48	50	35	35	11	12	M6	39	-	45	30	5	150	5.5	4,200	90	140
LMCL-C20						96		70					8							180	280
LMC-C25	25	60	33	2.5	60	65	40	40	14	12	M6	47	-	55	35	6	200	6.5	4,200	100	160
LMCL-C25						130		100					8							200	320
LMC-C30	30	70	37	5	70	70	50	50	15	18	M8	56	-	60	40	7	200	6.5	4,200	160	280
LMCL-C30						140		110					8							320	560
LMC-C40	40	90	48	7.5	90	90	65	65	20	20	M10	72	-	75	55	9	300	9	4,200	220	410